



MAYOR'S REPORT
March 19, 2025

BREMERTON
WASHINGTON



2025 City Reforestation Project

- Last week, Forestry completed planting 30,000 Seedlings
- This is a typical annual program - for 2025 the plantings included a mix of Douglas fir and Western red cedar
- Planting sites are recently harvested areas that help restore forest health by creating habitat as well as replacing dead and dying trees
- Sites are monitored by Forestry Staff for survival and invasive weed management



Quincy Square Update



- Quincy Square construction is underway and we anticipate substantial completion by early July
- The contractor began working on the reconstruction of the east side of 4th and Pacific which requires closure of intersection's crosswalks
- The detour directs pedestrians to use the crosswalks at 5th Street or Burwell Street
- 4th Street is still accessible to pedestrians and businesses are open!
- The closure will be in place for 3-4 weeks and ensures intersection and crosswalks will be completed and reopened before major events starting in early May



Quincy Square Update



Quincy Square



Pedestrian crossings at Pacific and 4th Street are closed.



ADA accessible crossing detours are at 5th and at Burwell.



4th Street is accessible to pedestrians!

Duration of closure is 3-4 weeks
**weather dependent*



Pre-approved ADU Plans



ARTISANS GROUP
ARCHITECTURE + PLANNING



SITE PLAN @ 1:20

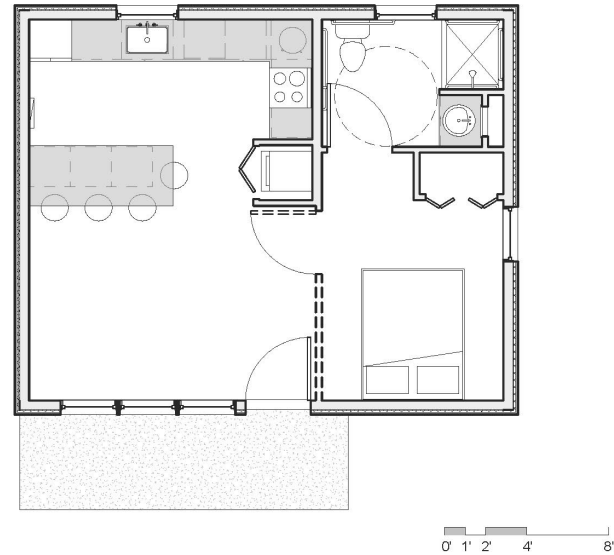
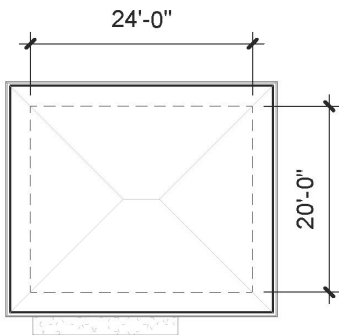

480 SF Studio

- Approximately 20' x 24' *
- Best suited for 1-2 people
- Roof & window styles can be customized
- Can be made into a one-bed dwelling
- Accessible Unit Layout

Thoughtfully designed for comfort and accessibility, the 480 SF ADU features zero-threshold entries, energy-efficient construction, and flexible layouts. Whether built on-site or prefabricated, they're the perfect small home, rental, or retreat.

* All overall dimensions are to exterior of framing

Pre-approved ADU Plans



ARTISANS GROUP
ARCHITECTURE + PLANNING

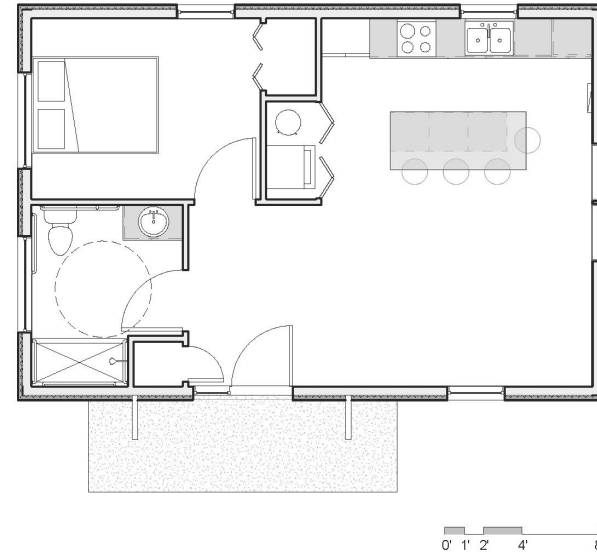

SITE PLAN @ 1:20

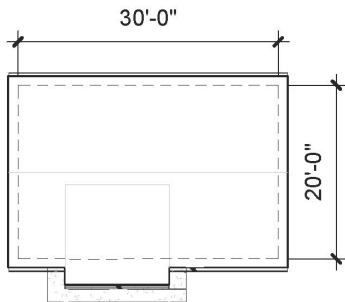

600 SF One Bedroom

- Approximately 20' x 30' *
- Best suited for 1-2 people
- Roof & window styles can be customized
- Accessible Unit Layout

Designed for flexibility and lasting comfort, this 600 SF ADU is a beautifully compact space for living, working, or creating. Featuring energy efficient detailing, aging-in-place considerations, and choices of classic roof styles and designs, it's small living without compromise.

* All overall dimensions are to exterior of framing

Pre-approved ADU Plans



ARTISANS GROUP
ARCHITECTURE + PLANNING

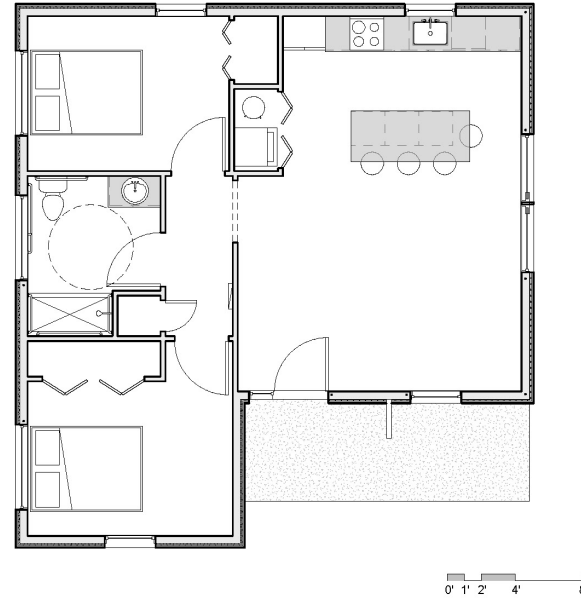

800 SF Two Bedroom

- Approximately 30' x 32' *
- Best suited for 1-4 people
- Roof & window styles can be customized
- Accessible Unit Layout

Thoughtfully crafted for everyday living, this 800 SF ADU maximizes every inch with a signature open floor plan, optional vaulted ceilings, and energy-efficient detailing. Whether home to a couple, a small family, or a first-time homeowner, it's a space that truly lives large!

* All overall dimensions are to exterior of framing

SITE PLAN @ 1:20

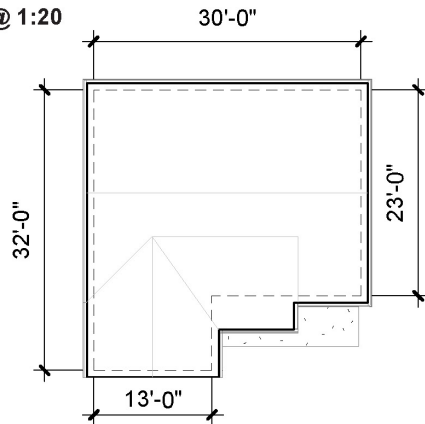

Pre-approved ADU Plans



ARTISANS GROUP
ARCHITECTURE + PLANNING

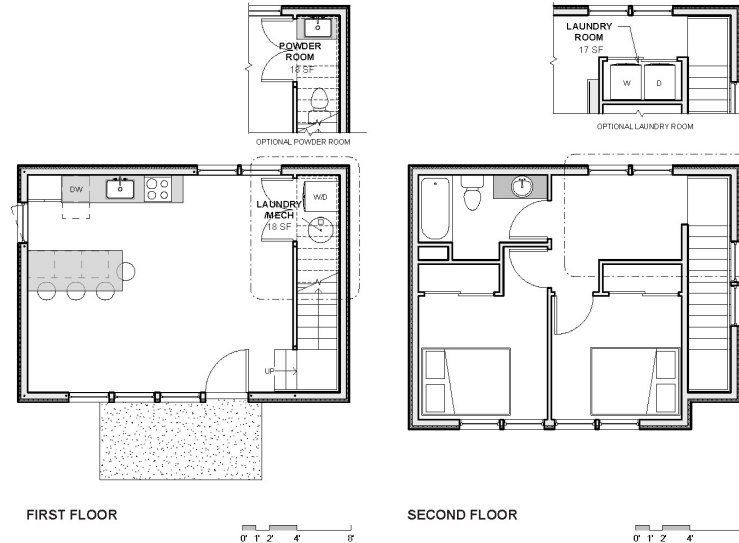

SITE PLAN @ 1:20

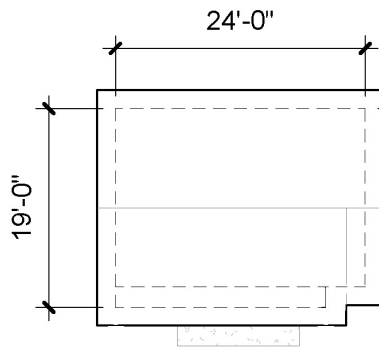

800 SF Two Bedroom - Two-Story

- Approximately 19' x 24' *
- Best suited for 1-4 people
- Roof & window styles can be customized
- 2-Story Unit Layout

Perfect for small lots, the 800SF02-story ADU offers 2 bedrooms, up to 1.5 baths, and numerous customization options. Its efficient layout with an open-concept design and large windows floods the space with natural light making it ideal for both everyday living and entertaining.

* All overall dimensions are to exterior of framing