

PIPE SIZE	DIMENSIONS (INCHES)				
	A	B	C	D	E
4"	2 ³ / ₈ "	4 ³ / ₄ "	17	13	14 ¹ / ₂ "
6"	3 ¹ / ₂ "	6 ⁷ / ₈ "	18	14	14 ¹ / ₂ "
8"	4 ¹ / ₂ "	9 ⁵ / ₈ "	19	15	14 ¹ / ₂ "
10"	5 ⁵ / ₈ "	11 ¹ / ₈ "	20	16	14 ³ / ₈ "
12"	6 ⁵ / ₈ "	13 ³ / ₄ "	21	17	14 ³ / ₈ "
14"	7 ³ / ₄ "	15 ¹ / ₄ "	22	18	14 ¹ / ₄ "
16"	8 ³ / ₄ "	17 ¹ / ₄ "	23	19	14 ¹ / ₄ "
18"	9 ³ / ₄ "	19 ¹ / ₄ "	24	20	14 ¹ / ₄ "

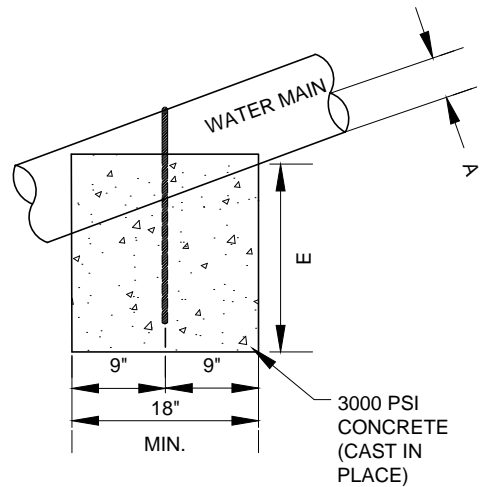
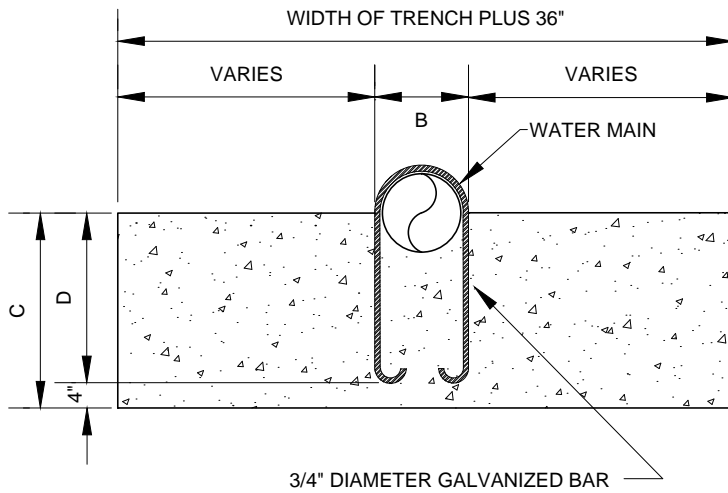

WHEN SLOPES ARE GREATER THAN 20% -
 PROVIDE CONCRETE SLOPE ANCHORS
 (20' TO 25' ON CENTER).

<p>City of Bremerton</p> <p><small>T:\ELSDN\logos\bwgrsy.BMP</small></p> <hr style="width: 50%; margin: 0 auto;"/> <p>PUBLIC WORKS</p> <hr style="width: 50%; margin: 0 auto;"/> <p>DESIGN/CONSTRUCTION STANDARDS</p>	<p>WATER MAIN CONCRETE SLOPE ANCHORS</p> <p style="font-size: small;">Alteration of this drawing is prohibited. Any approval of an altered drawing is unauthorized and void.</p>	<table border="1" style="width: 100%; border-collapse: collapse;"> <tr> <td style="font-size: large; font-weight: bold;">5331</td> </tr> <tr> <td style="font-size: small;">Revision Date 9/15/14</td> </tr> </table>	5331	Revision Date 9/15/14
5331				
Revision Date 9/15/14				