

DETAIL A
@ POST

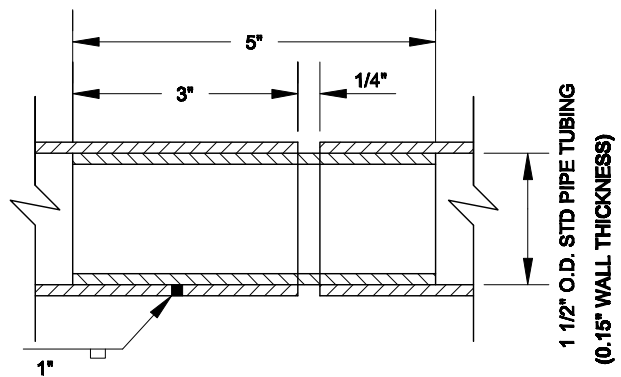

DETAIL B
SLIP JOINT DETAIL

3/4" SCH 40 (STD PIPE) BALUSTERS INSERTED IN HOLE AND TACK WELDED OPPOSITE TRAFFIC

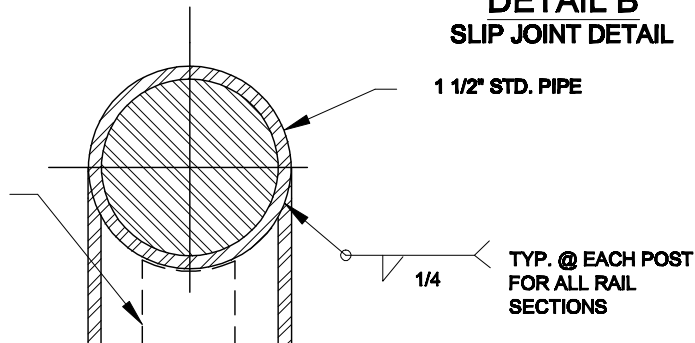

NOTES:

1. MATERIAL FOR PEDESTRIAN HANDRAIL SHALL BE ALUMINUM (ASTM B-429) OR HOT DIPPED GALVANIZED STEEL (ASTM 120) AS APPROVED BY THE CITY ENGINEER.
2. SEE STANDARD DRAWING 3302 FOR ADDITIONAL FABRICATION AND SPECIFICATION REQUIREMENTS.
3. PROVIDE SLIP JOINTS AT STAIRWAY EXPANSION JOINTS AND AT EVERY 24 FEET ON CENTER MAXIMUM.
4. MAXIMUM OF 4" CLEAR SPACE BETWEEN BALUSTERS



City of Bremerton

PUBLIC WORKS

ENGINEERING DIVISION

METAL SAFETY RAILING

Alteration of this drawing is prohibited. Any approval of an altered drawing is unauthorized and void.

3301

Revision Date

8/15/08